

- Elegante sistema todo en uno todo en uno POS
- Intel® Core rendimiento y eficiencia de última generación
- Monitor LED de 15" o 17" con tecnología Multi Touch PCAP
  - Impresora térmica integrada de 80mm recibos
- Acceso inmediato a los puertos de comunicación
  - Mantenimiento rápido sin herramientas
  - Disponible en blanco brillante o negro

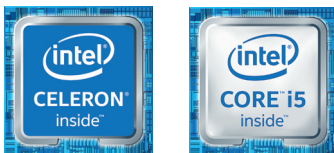

## Detalles Principales



### Efficiency & Potente

- Intel® Celeron® J1900 Quad-Core
- Intel® Core i5-series



### Impresora térmica

- Impresora térmica de recibos 80mm
- 200mm / s max Cortador automático



### Diseño innovador

- Diseño ergonómico e innovador
- Estructura de aluminio y acabados elegantes



### Pantalla de cliente VFD

- 20 Caracteres x 2 líneas



### Segunda pantalla LCD

- 12,1", 15" LCD
- Resoluciones 1024 x 768



### Lector Multi-estándar

- MSR (ISO 7811, Soporta 1 & 2 & 3 bandas de lectura)
- SCR (EMV Level 1 2)

## Características Técnicas serie POS 5500

General	
<b>Sistema</b>	
Procesador	Qs Intel® Core® i5-2520M (3M Cache, 2.50 GHz) J19 Intel® Celeron® J1900 (2GHz) Quad/Core FANLESS
Chipset	Qs Intel® HM76 J19 Intel® Bay Trail
Almacenamiento	SATA 3 (6Gb/s) 2.5" SSD 120GB, soporta AHCI
Memoria	4GB Standard (Max. 8GB) Type: DDR3L 1066MHz/s /Socket 2x SODIMM
Tarjeta Grafica	Intel® GMA HD integrada
Altavoz	2x 0.8W Stereo
<b>Impresora</b>	
Impresora Integrada	Impresora térmica de recibos de 80mm. 200mm/sec max, Cortador automático (Interfaz: Serial, USB)
<b>Monitor</b>	
Pannel	15" o 17" TFT LED retroiluminado
Resoluciones	1024 x 768 (15" - 1280 x 1024 (17"))
Luminosidad	300 cd/mq
<b>Táctil</b>	
Tipo	Táctil proyectivo Capacitivo (PCAP)
Interfaz de control	USB
<b>Puertos I/O Extremos</b>	
Video	1x VGA
USB	Qs 8x USB (4x USB 3.0 - 2x USB 2.0+2x USB lado) J19 8x USB (1x USB 2.0 - 4x USB 3.0+2x USB lado)
PS2	1
Serial	3 (COM 1~3 with 5V/12V power out 9 pins)
Ethernet	2x RJ-45
Audio	1x Line-out, 1x Mic-in
Power DC-IN	Qs 1 (connettore 3pin) J19
<b>Alimentación</b>	
	Qs Alimentación Externo 24V, 5A J19

<b>Sistemas Operativos Supportados</b>	
	Windows 7, Windows 8, Windows 10, POS Ready
<b>Características físicas</b>	
Temperatura di Operatività	0° ~ 50°C at 10% ~ 90% humedad
Temperatura de embalaje	-20° ~ 80°C at 10% ~ 90% humedad
Dimensiones (W x H x D)	364 x 382 x 285 (mm) (15") 392 x 410 x 346 (mm) (17")
Peso Neto	9,4 Kg (15") - 10Kg (17")
Dimensiones embalaje(WxHxD)	460 x 470 x 470 (mm) (15") 490 x 510 x 446 (mm) (17")
Peso embalaje	12.5 Kg (15") - 14.5 Kg (17")
Certificaciones	CE, FCC, KC,
<b>Opciones</b>	
Almacenamiento	2.5" SSD 240GB 2.5" HDD 500GB 2.5" HDD 1TB
2nd Disco Duro	2.5" SSD 120GB 2.5" SSD 240GB 2.5" HDD 500GB 2.5" HDD 1TB
I/O Expansiones	1 x Porta Paralela (D-SUB 25pins) 1 x Cassetto Portasoldi Port (RJ-11) 1 x Expansion Slot (mini PCIe per Wireless LAN) 1 x DVR Card (PCI 4 Canales)
Pantalla del Cliente (CDO)	VFD (20 caracteres x 2 lineas)
2nd Pantalla	12.1" 2nd LCD (1024 x 768 resoluciones) 15" 2nd LCD (1024 x 768 resoluciones)
Lector Magnetico	MSR: homologado ISO 7811, Soporta 1 & 2 & 3 bandas de lectura
Lector Smart Card	SCR: EMV level 1, 2
Dallas	Dallas I-button Lector

## Opciones



Impresora extraible



Lector (MSR, SCR)



Pantalla del Cliente VFD



Segundo Pantalla LCD

## Dimensiones

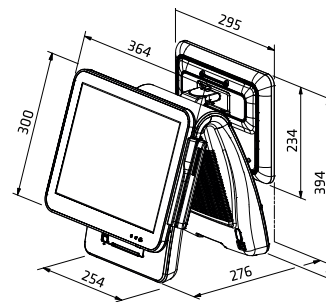

**axon**  
MICRELEC

HEADQUARTER  
Via Piersanti Mattarella, 32 - 30030 Gardigiano di Scorzè (VE) - Italy  
Tel. +39 041 5830594 - Fax +39 041 5830595  
www.apesse.com - info@apesse.com

IBERIA OFFICE  
Ortega y Gasset, 22 Planta 5 - 28002 Madrid  
Phone +34 91 047 2013  
commercial.iberia@apesse.com